

# FVM400 VECTOR MAGNETOMETER INSTRUCTION MANUAL

January 2018



**MEDA, Inc.**  
Macintyre Electronic Design Associates, Inc.  
43676 Trade Center Place, Suite 145  
Dulles, VA 20166

## TABLE OF CONTENTS

	Page
<b>INTRODUCTION AND SPECIFICATIONS .....</b>	<b>1</b>
<i>High Resolution .....</i>	<i>1</i>
<i>Two Vector Representations .....</i>	<i>1</i>
<i>Selectable Units .....</i>	<i>1</i>
<i>Relative Display Mode.....</i>	<i>1</i>
<i>Multiple Analog Outputs .....</i>	<i>1</i>
<i>Remote Operation .....</i>	<i>1</i>
<i>Data Recording .....</i>	<i>1</i>
<i>Specifications .....</i>	<i>1</i>
Technical Specifications .....	2
General Specifications .....	2
<b>OPERATING INSTRUCTIONS.....</b>	<b>3</b>
<i>Connecting the Probe .....</i>	<i>3</i>
<i>Applying Power .....</i>	<i>3</i>
<i>Power Down Mode.....</i>	<i>3</i>
<i>The LCD Display.....</i>	<i>3</i>
<i>Keypad Controls.....</i>	<i>4</i>
↑ or ↓.....	6
ALT.....	6
Calibrate.....	6
Coord .....	6
DAC.....	7
Gain.....	7
Manual .....	7
Pwr Dn .....	8
Record .....	8
Rel.....	8
Remote .....	9
RS232 .....	9
Sample.....	9
Screen.....	9
Snapshot.....	9
Suspend.....	9
Units .....	9

*Analog Output*..... 9  
*Sensor Configuration*..... 11  
REMOTE OPERATION ..... 12  
*RS232 Interface*..... 12  
*Commands* ..... 12  
MEASUREMENT TUTORIAL..... 14  
*Magnetic Field Units*..... 14  
*Vector Nature of Magnetic Fields* ..... 14  
*Earth’s Magnetic Field* ..... 15  
    The FVM400 as a Compass ..... 15  
    Measuring Earth’s Field ..... 16  
*Measuring the Static Magnetic Field of an Object* ..... 16  
THEORY OF OPERATION..... 20  
*Fluxgate Theory*..... 21  
*Analog Magnetometer* ..... 22  
*Signal Processing* ..... 22  
MAINTAINANCE ..... 24  
*Sensor Probe* ..... 24  
*Electronics Unit* ..... 24  
*Battery Replacement*..... 24  
*Cleaning Sensor Connectors and Cable Contacts* ..... 24  
*Battery Eliminator*..... 25  
*Calibration Schedule*..... 25  
WARRANTY ..... 26

**TABLE OF FIGURES**

	Page
Figure 1 FVM400 display format.....	4
Figure 2 FVM400 front panel.....	4
Figure 3 Definition of FVM400 coordinate systems.....	7
Figure 4 Analog output connector configuration and pin assignments.....	10
Figure 5 Physical location of fluxgate sensor elements (dimensions in inches).....	11
Figure 6 FVM400 representations of a magnetic field vector.....	14
Figure 7 Starting position when measuring the magnetic moments of an object.....	18
Figure 8 FVM400 functional block diagram.....	20
Figure 9 Ring core fluxgate operation.....	21
Figure 10 Simplified block diagram of one channel of the FVM400.....	22
Figure 11 FVM400 signal processing block diagram.....	23

**TABLE OF TABLES**

	Page
Table 1 Summary of FVM400 keypad commands.....	5
Table 2 Scale factor, range and resolution as a function of output gain.....	7
Table 3 RS232 D connector pin assignment.....	12
Table 4 List of remote commands.....	13
Table 5 Earth's magnetic field components at various US cities.....	16
Table 6 FVM400 replacement batteries.....	24

## INTRODUCTION AND SPECIFICATIONS

The FVM400 Vector Fluxgate Magnetometer is a precision instrument for measuring magnetic field vectors. Its small size and portability make it ideal for use in the field as well as in the laboratory.

### ***High Resolution***

The 5 digit display permits resolution of 1 nT in a 100,000 nT field. Thus small variations in magnetic field can be measured in the presence of a large field such as Earth's magnetic field.

### ***Two Vector Representations***

The user can display either the rectangular ( $X, Y, Z$ ) or polar ( $R, D, I$ ) components of the magnetic field. The polar representation is particularly convenient for measuring the magnitude and direction of the field. No manual calculations are required.

### ***Selectable Units***

The user can display the field magnitude in one of three common units: nanotesla (nT), microtesla ( $\mu$ T) or milligauss (mG). No need to remember the conversion factors.

### ***Relative Display Mode***

The relative display mode permits the measurement of changes in the magnetic field vector from an initial value. A simple press of the *Rel* key nulls the currently displayed value and, thereafter, displays the change from that value until the key is pressed again.

### ***Multiple Analog Outputs***

The raw analog magnetometer signals, as well as the processed signals, are available for recording or further processing through an 8-pin microDIN connector. The raw signals are useful for wideband AC field measurements. The processed signal outputs match the selected vector representation values. One of eight gains can be applied to the processed signal to provide higher output voltage resolution.

### ***Remote Operation***

The FVM400 can be controlled remotely through a standard RS232 serial connection operating at 9600 baud. In remote mode the user can set the measurement parameters, acquire a sample, initiate a data recording or retrieve previously recorded data.

### ***Data Recording***

The FVM400 has three data recording modes: *Snapshot*, *Record* and *Manual*. The *Snapshot* function records 7.5 seconds of data at a rate of 69.5 samples per second. The *Record* function stores 30 seconds of data at a rate of 17.4 samples per second. In *Manual* mode the user determines when to store a sample. The recorded data can be viewed on the display, sent to the analog outputs or retrieved remotely through the RS232 port.

### ***Specifications***

Specifications for the FVM400 are given in the following tables.

Technical Specifications

Field Measurements

Component	Range	Resolution	Accuracy <sup>1</sup>
X, Y, Z	±100,000 nT	1 nT	±(0.25% of reading + 5 nT)
R(esultant)	173,205 nT	1 nT	±(0.5% of reading + 5 nT)
D(eclination) <sup>2</sup>	±180 degrees	0.1 degree	1 degree
I(nclination) <sup>3</sup>	±90 degrees	0.1 degree	1 degree

<sup>1</sup> At 25°C ± 5°C. After correcting for zero field values. Maximum zero field value is 20 nT.

<sup>2</sup> The angle between the X axis and the projection of the field vector onto the XY plane.

<sup>3</sup> The angle between the field vector and the XY plane.

Analog Outputs

Parameter	DAC Output	Analog Magnetometer
Number	3 <sup>1</sup>	3 <sup>2</sup>
Gains	1,2,4,8,16,32,64,128	None
Voltage Range	±2.5 volts	±2.5 volts
Scale Factor	24.41 x gain μV/nT	24.41 μV/nT
Accuracy	±1% of full scale	±5% of full scale
Resolution	12 bits	Not applicable
Zero Field Output	0 ± 5 mV	0 ± 5 mV
Frequency Response	DC to 10 Hz nominal	DC to > 100 Hz

<sup>1</sup> Corresponds to actual or relative values based on the selected mode and coordinates.

<sup>2</sup> Corresponds to the actual rectangular component values.

Data Storage

Parameter	Snapshot	Record	Manual
Number of points	525	525	525
Duration	7.5 seconds	30 seconds	User determined
Sample Rate	69.5 samples per second	17.4 samples per second	User determined

**Serial Port:** Three wire RS232 port operating at 9600 baud, one start bit, one stop bit and no parity.

**Angular Alignment:** The X and Y axes sensors are aligned parallel to the base surface and along its length and width edges, respectively, to within ±0.25 degrees. The Z axis sensor is aligned normal to the base surface within ±0.25 degrees. This sensor arrangement represents a right-handed coordinate system.

General Specifications

**Temperature Range:** 0 to 50°C.

**Power:** Two nine volt batteries. Lithium is the preferred battery type but Alkaline can also be used. Nominal operating power consumption is 550 mW. Nominal power consumption when powered down is 20 mW.

**Operating Time:** Twenty-four hours continuous operation with Lithium batteries. Four hours continuous operation with Alkaline batteries. The FVM400 will power down after ten minutes of no keypad activity. In this state, the analog circuits are turned off to reduce battery drain. Pressing any key will bring the FVM400 back to life. The FVM400 can remain in the power down state for up to 150 hours before the Lithium batteries become exhausted.

**Probe Size:** 25.4 mm W x 25.4 mm H x 100.6 mm L (1"W x 1"H x 4"L).

**Electronics Case:** 100.1 mm W x 39.9 mm H x 196.1 mm L (3.94"W x 1.57"H x 7.72"L).

**Probe To Electronics Cable Length:** Seven feet standard. Other lengths are possible up to a maximum length of one hundred feet.

**Display:** Two lines by sixteen characters LCD. Viewing area dimensions are 60 mm L x 14 mm H (2.36"L x 0.54"H).

## OPERATING INSTRUCTIONS

This section provides instructions for operating the FVM400. The user controls the operation of the FVM400 through the power ON/OFF switch on the left side and the keys on the keypad of the electronics unit case. The LCD displays the measurement values and instrument state. The probe, which is connected to the electronics unit by a cable, contains the three magnetic field sensor elements that measure the three components of the magnetic field vector. The probe is placed at the location where the user wishes to measure the magnetic field vector. A microDIN connector, located on the right side of the electronics unit, can be used to connect the analog voltage signals from the FVM400 to an external recording device or oscilloscope. The FVM400 can also be controlled by a computer through a standard three-wire RS232 serial communications port.

### ***Connecting the Probe***

Before applying power to the FVM400, the probe must be connected to the FVM400 electronics unit using the supplied cable. It does not matter which end of the cable is connected to the probe or the electronics unit. Do not replace the cable or change its length. This action will invalidate the FVM400's calibration status.

### ***Applying Power***

The FVM400 power switch is located on the left side of the electronics unit. After power is applied to the FVM400, it will initialize to its default state: rectangular coordinate system and absolute measurement mode. The values of the X, Y and Z vector components will appear on the LCD display after about 2 seconds. If **O.L.** appears on the screen instead of a field value, turn power off, move the probe to a different location and turn the FVM400 back on. The FVM400 displays **O.L.** whenever any one of the vector components is beyond  $\pm 102,400$  nT or the probe is not connected to the electronics unit.

### ***Power Down Mode***

The power consumption of the FVM400 can be reduced substantially by using the power down function. The FVM400 will go into this state after ten minutes of keypad inactivity if the power down function has been enabled (the default state). The user can also place the FVM400 into the power down state or disable the power down function. See the section describing the front panel keypad controls.

In the power down state, field measurements are suspended, power to the analog circuits is turned off and the message "Press any key to start" appears on the LCD display. The FVM400 will return to its pre-power down state if any key is pressed. This is a convenient feature if the user wishes to monitor the change in the magnetic field over a period of time but only needs to sample the value periodically with a long time between samples. If the FVM400 was turned off between measurement intervals, the user would have to reset it to the desired measurement state each time power was reapplied. If the FVM400 is in the manual sample storage mode, the FVM400 must not be turned off while collecting the samples, but it can be put in the powered down state between samples to reduce battery power consumption.

### ***The LCD Display***

The FVM400 display consists of four lines of sixteen characters. The top three lines display the measured vector components. The bottom line displays the condition of the two batteries and status information.

Each component measurement row displays the component reference designator to the left of the measured value and the measurement units to its right. The far right column is the DAC output gain associated with the component. If the measurement mode is relative, a # will appear between the measured value and the units.

The bottom line displays the condition of the two batteries on the right side. If the power down mode is enabled (the default), an X will appear between the two battery condition displays.

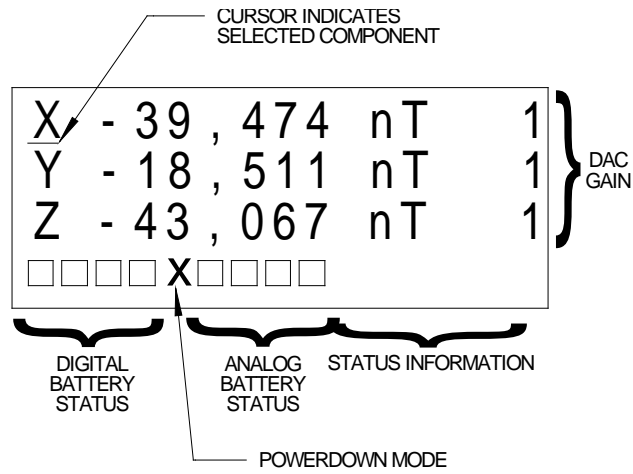

Figure 1 FVM400 display format

### Keypad Controls

Figure 2 below shows the FVM400 front panel keypad controls.

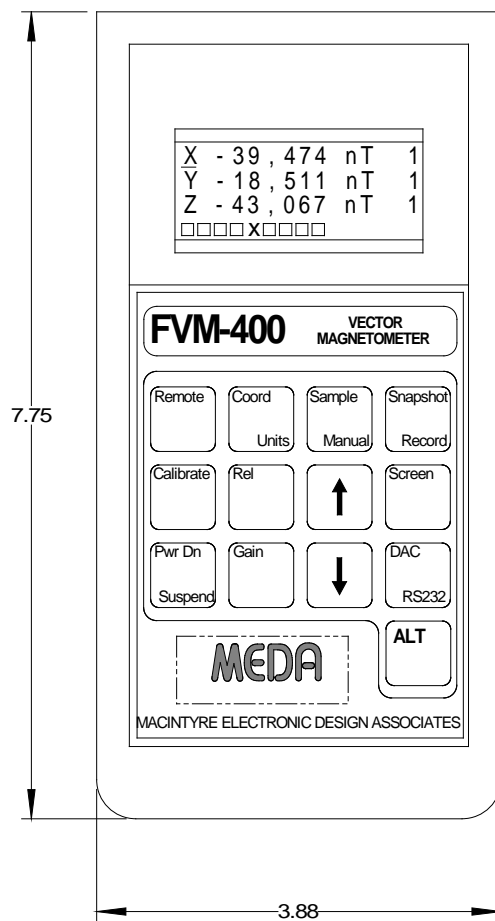

Figure 2 FVM400 front panel



The following table summarizes the FVM400 functions activated by pressing keys on the keypad.

*Table 1 Summary of FVM400 keypad commands*

<b>Key</b>	<b>Description</b>
↑	Selects the component that will be affected by pressing the REL or GAIN key. Also used to display the next stored sample.
↓	Selects the component that will be affected by pressing the REL or GAIN key. Also used to display the previous stored sample.
CALIBRATE	Outputs 0, +FS, -FS or stepped triangle to the display and the DAC outputs. This can be used to calibrate the DAC outputs or an external recording device.
COORD	Switches between rectangular (X, Y, Z) and polar (R, D, I) coordinate systems.
DAC	Replays the stored data through the DAC outputs.
GAIN	Selects one of eight DAC output gain settings for the selected component.
MANUAL <sup>1</sup>	Enables/disables manual data recording mode.
PWR DN	Enables/disables power down after 10 minutes of no key activity.
RECORD <sup>1</sup>	Initiates a 30 second data recording.
REL	Switches between absolute and relative measurement mode. In relative mode, the display shows the change in field from the initial value present when the key was pressed.
REMOTE	Switches between keypad control and remote RS232 serial port control.
REMOTE <sup>1</sup>	Sends text data continuously out the RS232 serial port at a rate of 4 samples per second. The status line displays Text on the right side. The output data format is shown below. Pressing REMOTE again stops the outputting of data and returns the instrument to local mode.  @-009563+049074+020558
RS232 <sup>1</sup>	Sends the stored data out the RS232 port.
SAMPLE	Stores a single data point. Must be in Manual recording mode.
SCREEN	Displays the stored data on the LCD. Use the arrow keys to move from one sample to another.
SNAPSHOT	Initiates a 7.5 second data recording.
SUSPEND	Powers down the FVM400 to conserve battery capacity. Hitting any key while the FVM400 is powered down will return it to normal operation.
UNITS <sup>1</sup>	Selects nT, μT or mG as the displayed units.

<sup>1</sup> The ALT key must be pressed first to activate this function.

↑ or ↓

Use the UP and DOWN arrows to select the active component. The active component is the one with an underscore. The REL and GAIN key functions only apply to the active element. These keys are also used to display the next or previous sample stored in the FVM400 internal buffer when inspecting the data on the LCD display.

### ALT

Pressing the ALT key changes the functions of the keys on the keypad to the ones printed in the lower right-hand corner. The standard keypad functions are printed in the upper left-hand corner of each key. After pressing the ALT key, an ^ will appear to the right of the battery status indicators. The ^ will disappear after a key is pressed or if the ALT key is pressed again.

### Calibrate

The Calibrate keypad function sends signals to the DAC analog outputs that can be used to calibrate externally attached recorders or data acquisition equipment. A zero (0) value is sent to the display and all three DAC outputs the first time the key is pressed. The next press of the key outputs a +FS (100,000 nT) value to the display and DACs. The third time the key is pressed, a -FS value is sent to the display and DACs. The fourth press of the key initiates a stepped triangular signal. The signal begins at +FS. The signal decrements by 20,000 nT every second until it reaches 0, where it pauses for two seconds, and then proceeds at one second intervals down to -FS. It remains at -FS for two seconds and then increases to +FS in 20,000 nT steps until it reaches 0, where it remains for two seconds. It then continues upward until it reaches +FS. This sequence is repeated until the Calibrate key is pressed again to return the FVM400 to normal operation.

### Coord

Pressing the Coord key switches the displayed components between rectangular and polar coordinate systems. The coordinate systems are defined with respect to the sensor probe as shown in Fig. 3. In the rectangular coordinate system mode, positive readings indicate that the field vector component is pointing in the same direction as the corresponding arrow.

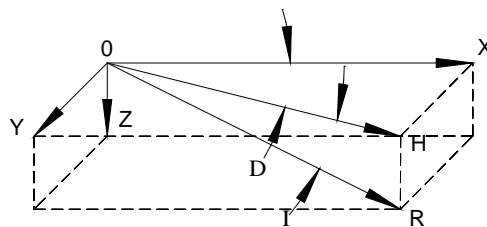

1). COORDINATE SYSTEMS DEFINITION

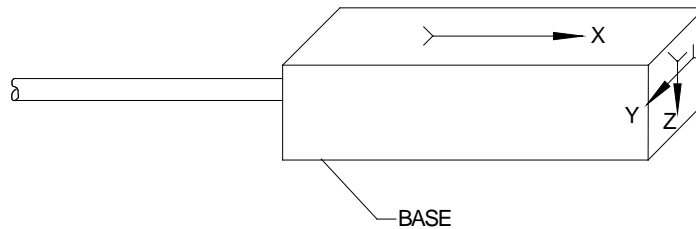

2). COORDINATE SYSTEM REFERRED TO PROBE BASE

Figure 3 Definition of FVM400 coordinate systems

In the polar coordinate system mode, the *R*(esultant) component is the magnitude of the field, and the *D*(eclination) and *I*(nclination) angles indicate the direction of the field vector relative to the base. *D* is defined as the angle between the *X* axis and the projection of the field vector onto the base surface. A positive angle indicates that the projection is rotated clockwise with respect to the *X* axis. The *D* angle ranges from –180 degrees to + 180 degrees. *I* is defined as the angle between the field vector and the base surface. A positive value indicates that the field vector is pointing down with respect to the base surface. The *I* angle ranges from –90 degrees (pointing up) to + 90 degrees (pointing down).

## DAC

Pressing the DAC key causes the data stored in the internal FVM400 buffer to be sent to the processed analog outputs. While the data is being output, **Buffer→DAC** is displayed on the bottom line. The data is output at the same sample rate that it was stored, so a Snapshot recording will take 7.5 seconds to output while a Record recording will take 30 seconds. Before pressing the DAC key, the user can set the gain for each vector component by using the *Gain* and arrow keys. The *Gain* key section discusses the effect of the gain setting on output scale factor, range and resolution.

## Gain

The *Gain* keypad function sets the gain of the DAC output associated with the active component. The *Gain* function determines the DAC output scale factor ( $\mu\text{V/nT}$ ) and dynamic range. The scale factor is the product of the gain and the scale factor at a gain of 1. The full scale range of the output is inversely proportional to the gain. A DAC output of a component with an associated gain of 1 has a full scale output range of 100,000 nT, whereas a DAC output of a component with an associated gain of 2 has a full scale output range of 50,000 nT and so on. The resolution of the DAC outputs is 12 bits (1 part in 4096). The following table lists the scale factor, range and resolution for each of the eight possible gain settings.

Table 2 Scale factor, range and resolution as a function of output gain

Gain	Scale Factor ( $\mu\text{V/nT}$ )	Range (nT)	Resolution (nT)
1	24.41	$\pm 100,000$	50.00
2	48.83	$\pm 50,000$	25.00
4	97.66	$\pm 25,000$	12.50
8	195.3	$\pm 12,500$	6.25
16	390.6	$\pm 6,250$	3.13
32	781.3	$\pm 3,125$	1.56
64	1.56 mV/nT	$\pm 1,563$	0.78
128	3.13 mV/nT	$\pm 781$	0.39

Each time the *Gain* key is pressed, the gain will increase by a factor of two until the gain is 128. Pressing the key once more returns the gain to 1.

To output high resolution measurements of field changes to the DACs, use the *Rel* key to null the initial field value. Then increase the gain to a value that provides the greatest resolution for the range of the expected field change.

## Manual

Pressing the *ALT* key followed by the *Manual* key places the FVM400 in the manual sampling mode. The keypad is disabled (except for the *Manual*, *Sample*, and *Suspend* functions) during the recording period, and **Man** appears on the bottom line. The three components of the field vector are sampled and stored at a rate determined by the user. The stored values depend on the selected coordinate system and the measurement mode (ABS or REL) of each

component when the manual sampling mode is entered. The user stores a value by pressing the *Sample* key. The three characters to the right of **Man** on the bottom line indicate the number of samples that have been stored. To stop manual data storage, press the *ALT* key followed by the *Manual* key again.

When the *Manual* storage mode is first started, zeros are placed in the storage buffer. Thereafter, whenever the *Sample* key is pressed, a data point is stored in the buffer and the sample counter is incremented. After completing the manual data storage activity, do not start a new data storage function until the data has been transferred to an external device or hand recorded. Starting a new data storage function (*Snapshot*, *Record* or *Manual*) will erase all the data in the storage buffer. The FVM400 power can be turned off without losing the stored data.

If the time interval between manual samples is substantial (e.g., several minutes), battery life can be extended by powering down (not turning off) the FVM400 (see the *Suspend* subsection). When the FVM400 is revived from the power down state, it will be restored to its pre-power down operating state, and manual data storage can continue.

Do not turn the FVM400 off until all manual samples have been collected, instead use the *Suspend* feature to conserve battery life.

### Pwr Dn

Pressing the *Pwr Dn* key toggles between enabling and disabling the power down function. The power down mode significantly reduces the power consumption of the FVM400 and increases battery life.

If the power down function associated with keypad inactivity has been enabled (the default condition when power is first applied to the FVM400), the FVM400 will go into the power down state after ten minutes of keypad inactivity.

If the power down function is disabled, the FVM400 will remain fully powered and functioning until the power switch is turned off or the power down function is enabled. An X is displayed between the two battery status indicators when the power down function is enabled.

Pressing any key while in the power down state will bring the FVM400 back to the pre-power down measurement state. If a displayed vector component was in the relative measurement mode, the displayed value will be the change in the field from the time it was placed in relative mode. If the FVM400 was in the manual sampling mode when entering the power down state, it will return to that mode allowing the user to continue collecting manual samples.

### Record

Pressing the *ALT* key followed by the *Record* key initiates a 30 second data recording. The keypad is disabled during the recording period, **Rec** appears on the bottom line and the elapsed time in seconds appears to its right. The three components of the field vector are sampled and stored at a rate of 17.4 samples per second. The stored values depend on the selected coordinate system and the measurement mode (ABS or REL) of each component.

### Rel

Pressing the *Rel* key switches the measurement mode of the active component (see ↑ and ↓) between absolute and relative. A # symbol will appear between the measurement value and the units when in relative mode. In the relative mode the value of the displayed field component, at the time the key is pressed, is stored and subtracted from subsequent measurements. While in relative mode, the displayed value is the change in field from this initial value. The range of the change that can be measured depends on the initial value as given by the following equations:

$$\text{Maximum positive change} = +100,000 \text{ nT} - \text{initial field value}$$

$$\text{Maximum negative change} = -100,000 \text{ nT} - \text{initial field value}$$

The measurement mode only applies to the underscored component. The measurement mode for each component can be set independently. For example, the X and Y components could be in absolute mode while the Z component is in relative mode.

The DAC analog output depends on the measurement mode and the gain specified for the displayed component. See the discussion in the *Gain* key section.

### Remote

Pressing the *Remote* key switches the FVM400 between local and remote modes. In remote mode **Rem** appears on the bottom line of the display. The keypad is disabled (except for the *Remote* key) when in remote mode, and the FVM400 only responds to commands received through the RS232 communications port. Also, the power down function is disabled. Remote operation is described in the next section.

### RS232

Pressing the RS232 key sends the data stored in the FVM400 internal buffer out the RS232 port. **Memory→RS232** appears on the bottom line while the data is being output. See the next section for a description of the data format.

### Sample

This function is active only while in manual sample mode. Pressing the *Sample* key stores the current values of the field components and increments the stored data point count on the display. The stored values depend on the selected coordinate system and the measurement mode (ABS or REL) of each component.

### Screen

Pressing the *Screen* key causes the values of the first stored sample to be displayed. The right three characters of the bottom line display the sample number. Pressing the  $\uparrow$  key increments the sample number and displays the next sample values. Pressing the  $\downarrow$  key decrements the sample number and displays the previous sample value.

Viewing all the stored samples using the manual inspection technique can be tedious. A more convenient way to see the data is to send it to the DAC analog outputs or through the RS232 port to a computer terminal.

### Snapshot

Pressing the *Snapshot* key initiates a 7.5 second data recording. The keypad is disabled during the recording period and **Snp** appears on the bottom line. The three components of the field vector are sampled and stored at a rate of 67.5 samples per second. The stored values depend on the selected coordinate system and the measurement mode (ABS or REL) of each component.

### Suspend

Pressing the Suspend key causes the FVM400 to immediately power down, and the message **Press any key to start** appears on the display. When the FVM400 is in the power down state, pressing any key will return the FVM400 to its pre-power down state. This is a convenient function to use to conserve battery power while collecting manual samples where the sample interval might be several minutes or longer.

### Units

The user selects the magnetic field units in which to display the field value by pressing the *ALT* key first and then the *Units* key. The order of units selection is nT- $\mu$ T-mG-nT. The selected units apply for all displayed field values.

### **Analog Output**

The analog output signals are available through an eight pin microDIN connector on the right side of the FVM400. Figure 4 shows the connector mechanical configuration and the pin assignments. The analog magnetometer output signals are not calibrated, but their accuracy is better than  $\pm 5\%$ . The outputs correspond to the values of the rectangular components of the magnetic field vector. Also the output range and scale factor are fixed. The frequency response of the analog magnetometer is greater than 100 Hz, therefore, its analog outputs are useful when

## FVM400 VECTOR MAGNETOMETER

making measurements where the signal frequency is beyond the 10 Hz limit of the basic FVM400 digitally processed signals.

The DAC output signals are derived from the calibrated signals digitally processed by the FVM400. The DAC output scale factors, ranges, resolutions and vector component associations are determined by the selected coordinate system, individual component gains and the individual component measurement modes (ABS or REL). See the *Gain* key section for a discussion of how these outputs are affected by gain. See the *Rel* key section for a description of how the measurement mode affects the DAC outputs.

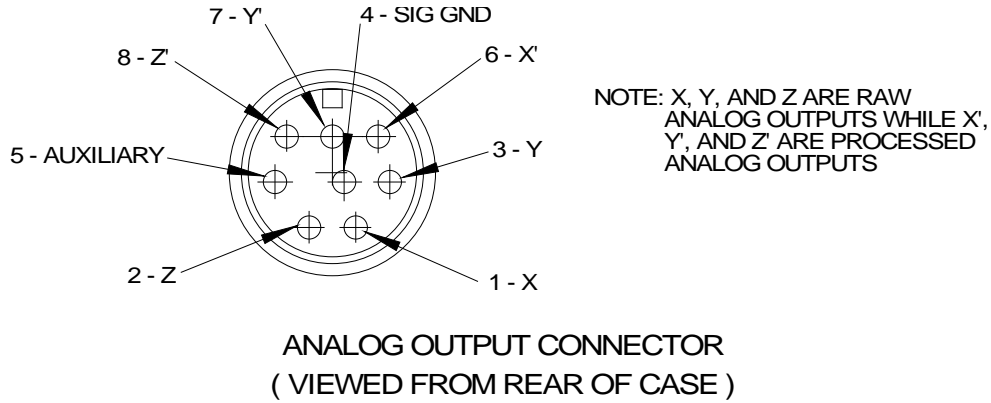

*Figure 4 Analog output connector configuration and pin assignments*

NOTE: When Polar Coordinates are selected for display, the  $X'$ ,  $Y'$  and  $Z'$  DAC outputs correspond to the  $R$ ,  $D$ ,  $I$  value.

### ANALOG OUTPUT COORDINATES

PIN	RECTANGULAR	POLAR
6	$X'$	$R$
7	$Y'$	$D$
8	$Z'$	$I$

**Sensor Configuration**

Figure 5 shows the location of the fluxgate sensor elements relative to the tip of the sensor.

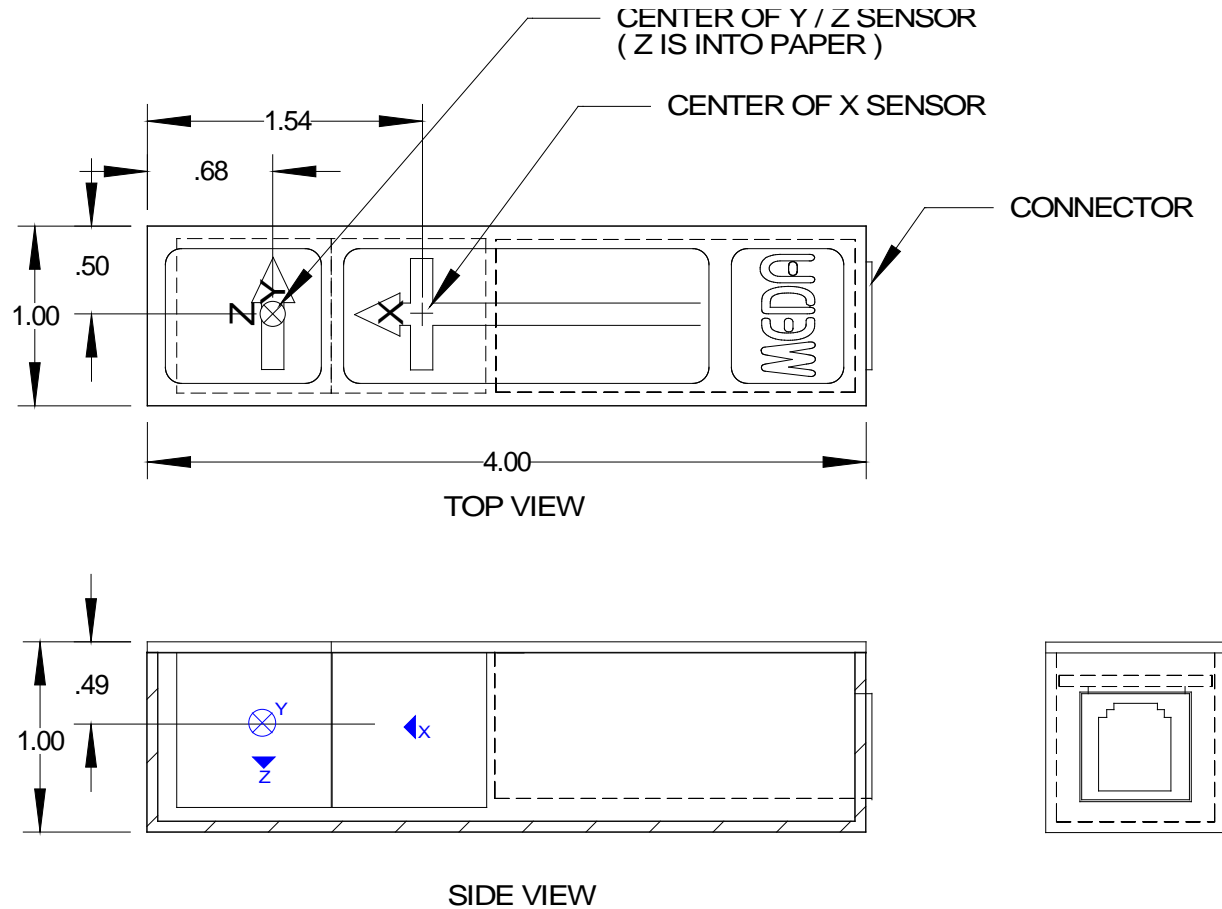

*Figure 5 Physical location of fluxgate sensor elements (dimensions in inches)*

The sensor consists of two ring core fluxgate elements. One ring core has two signal windings oriented at right angles to one another. These windings measure the Y and Z magnetic field vector components. The second ring core, which has a single winding and is oriented at right angles to the first ring core, measures the X component of the magnetic field vector. The sensor is connected to the electronics unit by means of a simple standard RJ45 8-conductor modular flat cable.

During calibration the sensor axes alignment is measured relative to the sensor case bottom surface and front edge. The measured components are then corrected digitally using a matrix transformation. The corrected vector components are the ones displayed on the screen and used to compute the polar coordinates.

## REMOTE OPERATION

This section describes how the FVM400 can be controlled by a remote computer through the RS232 interface. The FVM400 can return a single sample, initiate a *Snapshot* or *Record* operation, set/get the coordinate system, set/get the displayed component, set/get the measurement mode, dump the contents of the recorded data buffer and set the FVM400 to a known default state.

### **RS232 Interface**

The FVM400 comes with an adapter cable, which has a three contact mini phone plug on one end that plugs into the FVM400 and a twenty five (25) pin female D connector on the other end that connects to the remote computer or terminal. The D connector wiring is compatible with the serial communications (com) port found in IBM PC compatible computers. It is configured for DTE operation. Only three wires are used and there is no hardware or software handshaking.

*Table 3 RS232 D connector pin assignment*

Pin	Signal	Description
2	TX	Transmitted data from the FVM400
3	RX	Received data from the computer or terminal
7	SG	Signal ground

The data is transmitted at a 9600 baud rate with one start bit, eight data bits, no parity bit and one stop bit. All data bytes are printable ASCII characters, the carriage return <cr> control code (0AH) or the end of transmission <EOT> control code (04H), which is used to indicate the end of data transmission from the FVM400.

### **Commands**

The commands sent to the FVM400 consist of ASCII character strings from one to three characters long. Responses from the FVM400 consist of an ASCII character string followed by the <EOT> control code. If the command is accepted, an 'A' is returned immediately, otherwise an 'E' is returned. To transmit commands and receive responses, the FVM400 must be in the remote mode, otherwise there will be no response from the FVM400 when a command is sent. The FVM400 is placed in the remote mode by pressing the *Remote* key. **Rem** will appear on the bottom line of the display while the FVM400 is in the remote mode, and the keypad will be disabled except for the *Remote* key. Pressing the *Remote* key a second time returns the FVM400 to local control. The following table lists the commands and the FVM400 responses.



Table 4 List of remote commands

Command	Description	Response
*	Set the FVM400 to the default state: rectangular coordinate system, X component, absolute measurement mode.	A<EOT>
?	Take one sample and return the three component values of the selected coordinate representation. Values will be absolute or relative based on the selected mode for the component.	A<EOT> <comp 1>, <comp 2> ,<comp 3><cr>D<EOT>
D	Transmit the data that was recorded using the <i>Snapshot</i> , <i>Record</i> or <i>Manual</i> sampling functions.	A<EOT> <type> <sup>1</sup> <coord> <sup>2</sup> <mode> <sup>3</sup> <comp 1>, <comp 2>, <comp 3> <cr> ... <comp 1>, <comp 2>, <comp 3> <cr> D<EOT>
GM	Get the current measurement mode for the displayed component.	A0D<EOT> if absolute A1D<EOT> if relative
GC	Get the current displayed component. The component depends on the selected coordinate system.	A0D<EOT> if X or R A1D<EOT> if Y or D A2D<EOT> if Z or I
GX	Get the current selected coordinate system.	A0D<EOT> if rectangular A1D<EOT> if polar
SM0	Set the displayed component measurement mode to absolute.	A<EOT>
SM1	Set the displayed component measurement mode to relative.	A<EOT>
SX0	Set the coordinate system to rectangular.	A<EOT>
SX1	Set the coordinate system to polar.	A<EOT>
SC0	Set the displayed component to X or R depending on the selected coordinate system.	A<EOT>
SC1	Set the displayed component to Y or D depending on the selected coordinate system.	A<EOT>
SC2	Set the displayed component to Z or I depending on the selected coordinate system.	A<EOT>
RS	Take a <i>Snapshot</i> recording. A “D” followed by the <EOT> control character is sent after the process is finished.	A<EOT>D<EOT>
RR	Take a <i>Record</i> recording. A “D” followed by the <EOT> control character is sent after the process is finished.	A<EOT> D<EOT>

<sup>1</sup><type> can be ‘S’ for *Snapshot*, ‘R’ for *Record* or ‘M’ for *Manual*.

<sup>2</sup><coord> is 0 for rectangular or 1 for polar.

<sup>3</sup><mode> indicates the measurement mode. 0 – all actual, 1 – comp 1 relative, 2 – comp 2 relative, 3 – comp 1 & 2 relative, 4 – comp 3 relative, 5 – comp 1 & 3 relative, 6 – comp 2 & 3 relative, 7 – all comp relative.

## MEASUREMENT TUTORIAL

This section discusses techniques which will help improve the effectiveness and accuracy of magnetic field measurements.

### **Magnetic Field Units**

The units commonly used within the scientific community to specify the strength of a weak magnetic field are nanotesla (nT) or gamma ( $\gamma$ ). Magnetic field magnitudes are often stated in milligauss (mG) or microtesla ( $\mu\text{T}$ ). The strength of a strong magnetic field is usually given in Gauss (G), Oersted (Oe), or Tesla (T). Another unit which is used is the Ampere/meter (A/m).

These different units of measurement frequently cause confusion among users of magnetic field measuring instruments. All of these units are interrelated. Only the Oersted and the Ampere/meter are proper units for specifying magnetic field strength. The other units specify flux density which is related to magnetic field strength through a material property called permeability. It so happens that the permeability of air is one (1) in the cm-g-s (cgs) system, and most measurements are made in air. Under these circumstances, the flux density magnitude and field strength magnitude are the same and are sometimes reported using the units interchangeably. The relationships between the units are given below:

$$1 \text{ nT} = 1 \gamma$$

$$1 \text{ G} = 10^5 \gamma$$

$$1 \text{ A/m} = 4\pi \times 10^{-3} \text{ Oe}$$

$$1 \text{ T} = 10^4 \text{ G}$$

$$1 \text{ mG} = 0.1 \mu\text{T}$$

The FVM400 allows the user to select nT,  $\mu\text{T}$  or mG as the unit of magnetic field strength to display.

### **Vector Nature of Magnetic Fields**

Magnetic fields are vectors. At any point in space a magnetic field has a magnitude and a direction. This is illustrated in Fig. 6. A vector is usually represented graphically by an arrow which indicates the direction of the vector and has a length which is proportional to the vector magnitude. A magnetic field vector can be separated into three component vectors (X,Y,Z) which are at right angles to one another. These are called the rectangular components of the vector. The magnitude of the vector is determined by squaring the component vector magnitudes, summing the squares and then taking the square root of the sum. A vector may also be described in terms of its magnitude  $R$  and angles  $D$  and  $I$ . These are called its polar coordinate components.

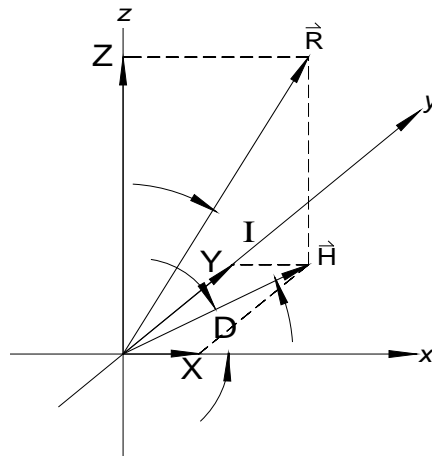

Figure 6 FVM400 representations of a magnetic field vector

Arrows on the probe top and end indicate the FVM400 reference rectangular coordinate system. It is a right-handed system. The arrows indicate the direction of the field vector which produces a positive FVM400 reading when measuring a rectangular component of the vector. The vector component measurements displayed on the LCD are referred to this coordinate system.

The rectangular and polar components of the vector are related to one another. Use the following equations to convert from one set of components to the other:

$$X = H \cdot \cos D$$

$$Y = H \cdot \sin D$$

$$Z = R \cdot \sin I$$

$$H = \sqrt{(X^2 + Y^2)}$$

$$R = \sqrt{(X^2 + Y^2 + Z^2)}$$

$$D = \tan^{-1}(Y/X)$$

$$I = \tan^{-1}(Z/H)$$

The FVM400 can display the vector components in either of these two coordinate system representations.

### ***Earth's Magnetic Field***

We are immersed in a static magnetic field produced by the Earth. The presence of this field both helps us and hinders us in the measurement of magnetic fields. We are all familiar with compasses. The compass needle is itself a magnet and, when placed in Earth's magnetic field, it points toward the north magnetic pole which coincidentally is very near the geographic north pole. This is a useful property of the Earth's field since it allows us to orient ourselves everywhere on Earth except at the poles themselves. The FVM400 can be used as a compass to determine the direction of magnetic north.

The Earth's magnetic field also helps us find hidden objects. Many objects are made of ferromagnetic materials which can be permanently or temporarily magnetized when subjected to a magnetic field. Water pipes, light poles, automobiles and many appliances fall into this category. Normally the Earth's field is very uniform over a large area, but these kinds of objects produce a reaction magnetic field which causes a distortion in the Earth's field near them. This is an advantage when we want to find a buried or hidden object. We can measure the magnetic field at various points and look for variations in uniformity. A spatial plot of the changes in the field will produce a "magnetic signature" which can be recognized and used to pinpoint the object's location.

The following sections describe procedures for using the FVM400 to locate magnetic north and measure the Earth's field characteristics at the user's location.

### **The FVM400 as a Compass**

The FVM400 can be used as a compass to determine magnetic north. For best results, remove all ferromagnetic objects such as keys, belt buckles and watches from your body before making the measurement. Use the following procedure to establish magnetic north:

1. Switch the FVM400 on.
2. Press the *Coord* key to place the FVM400 into the polar coordinates mode.
3. With the base of the probe held horizontally and the *X* axis arrow on top of the probe, slowly rotate the probe in the horizontal plane (about the *Z* axis) until the value of the *D* component reading goes to zero. The *X* axis arrow on top of the probe is now pointing towards the magnetic north pole.

### Measuring Earth's Field

The components of the Earth's field vector can be measured using the FVM400. The magnitude of the field vector can be found directly by following steps 1 and 2 in the previous section and then recording the *R* component as the Earth's field vector magnitude. This does not produce the most accurate result. Angular misalignment of the sensor elements inside the FVM400 probe may produce errors. Use the following procedure to get the most accurate measurement of the Earth's magnetic field vector magnitude:

1. Follow the steps listed above.
2. With the probe pointing north, press the *Coord* key to place the FVM400 into the rectangular coordinate mode.
3. Record the *X* component measurement as the horizontal component of the field. The *Y* component value should be very close to zero.
4. Return to the polar coordinate mode. Record the *I* component as the dip or inclination angle of the field.
5. Slowly dip or elevate the probe until the *I* component value reaches zero.
6. Press the *Coord* key until the *X*, *Y* and *Z* components appear. Record the *X* component value as the magnitude of the Earth's field vector.

The measurement of the magnitude of the Earth's field vector will be very accurate using this method, but the dip and horizontal field component measurements will not be quite as accurate, since they depend on the angular deviation of the probe from the horizontal plane. To achieve the best possible horizontal component and dip angle results, use a non-magnetic surface and use a level to verify that the surface is horizontal.

The table below lists the nominal Earth's field vector characteristics for various cities throughout the U.S.

*Table 5 Earth's magnetic field components at various US cities*

<b>City</b>	<b>H (nT)</b>	<b>Z (nT)</b>	<b>R (nT)</b>	<b>I (deg.)</b>	<b>D (deg.)</b>
Washington, D. C.	20,535	49,866	53,929	67	-13
New York, NY	19,508	51,553	55,121	69	-13
Miami, FL	25,721	39,768	47,360	57	-3
Chicago, IL	18,643	53,922	57,054	71	-1
Denver, CO	21,509	50,636	55,015	67	11
San Francisco, CA	20,609	49,755	53,854	67.5	19
Los Angeles, CA	25,283	42,260	49,246	59	14
San Diego, CA	25,674	41,413	48,726	58	14
Seattle, WA	19,208	52,742	56,131	70	20
New Orleans, LA	24,797	43,902	50,421	61	2
Boston, MA	18,881	52,003	55,324	70	-16

The values given in this table are referenced to the geodetic coordinate system. The FVM400 can be used to locate geodetic north at any of these cities by rotating the sensor in the horizontal plane until the *D* component of the FVM400 has the same value as the one in the table.

### **Measuring the Static Magnetic Field of an Object**

The FVM400 can be used to determine if an object is magnetized and to measure the static field it produces. Magnetized objects have static fields which diminish rapidly with distance. Doubling the distance between the

object and probe usually results in the measured field magnitude dropping to 1/8 of its original value (the field drops off as  $1/r^3$  where  $r$  is the distance from the object to the measuring point).

The distortion in Earth's field caused by a magnetized object extends only a short distance from the object. The stronger the object is magnetized, the further away it can be detected. The fields of permanent magnets can be measured by the FVM400 at relatively large distances. Objects which are magnetized by Earth's field usually have much smaller magnetic fields and must be close to the FVM400 to be detected.

Because the magnetized object is immersed in Earth's field, the field measured by the FVM400 is the sum of both fields; so a technique is needed which will extract the object's magnetic characteristics from the measurements. Measurements of the changes in the local Earth's field caused by the presence of the object will achieve this objective. Measuring the changes in the rectangular components is the best way to characterize the magnetic properties of an object. Since the rectangular component values change as the probe is moved in Earth's field, the best strategy for making measurements is to keep the FVM400 probe in a fixed position while moving the object being measured towards or away from the probe.

Objects can have some permanent magnetization and some magnetization induced by Earth's field. The permanent magnetization is not dependent on the presence of a magnetic field for its existence. As the object rotates, the field produced by the permanent magnetization will rotate. The induced magnetization depends on the direction and magnitude of the Earth's magnetic field vector and the magnetic properties of the object. If the object is magnetically homogeneous and isotropic (same properties in all directions), the induced magnetization will be proportional to and in the direction of the Earth's field. The field caused by the induced magnetization will not rotate as the object is rotated. The relative contributions of these two magnetizations can be determined through a series of measurements which involve rotations of the object.

If the magnetized object is sufficiently far away from the FVM400 probe (at least twice the length of the object's longest dimension), the field it generates can be approximated by assuming that the object may be modeled as two magnetic dipoles: one which represents the permanent magnetization and the other which represents the induced magnetization.

The property of a magnetic dipole, which determines the field that the object generates, is a vector called the magnetic dipole moment. The dipole moment vector is the sum of the permanently magnetized dipole moment vector ( $m_{x_p}, m_{y_p}, m_{z_p}$ ) which is fixed relative to the coordinate system associated with the object, and the induced dipole moment vector ( $m_{x_i}, m_{y_i}, m_{z_i}$ ) which is fixed relative to the Earth's field coordinate system. The items in parentheses are the rectangular components of the vectors in their respective coordinate systems. If the values of these components are known, the field generated by the object can be computed using equations which can be found in standard textbooks on magnetostatics. The series of measurements that are described in the following procedure are designed to determine the values of these components.

### Data Collection

1. Determine the geometric center of the object to be tested. This is the pivot point about which all rotations are to be made.
2. Assign the longest dimension of the object to be the  $X$  axis ( $X$  dimension), and draw a straight line on the object to represent this axis with an arrow head at one end of the line.
3. Assign two more axes, called  $Y$  and  $Z$ , which are at right angles to the  $X$  axis and to themselves. Indicate the axes' directions using straight lines with arrow heads drawn on the object. Make sure this reference coordinate system is right-handed.
4. Secure the FVM400 probe on a flat horizontal surface with the  $X$  axis arrow on the top of the probe.
5. Select the rectangular coordinate system.
6. With the object to be measured well removed from the probe, set each of the components in the REL measurement mode. The component readings should now be close to zero.

7. Place the object along the projection of the probe's X axis so that the distance, between the center of the object and the crosshairs indicating the center of the X axis sensor, is twice the length of the X dimension of the object (see Fig. 7 below).
8. Rotate the object so that the X, Y and Z axes of the probe and the object coincide. The probe and object axes arrows should be pointing in the same direction (see Fig. 7).
9. Measure and record the distance  $s$  from the probe X axis sensor center to the object's center. Repeat for the probe Y and Z axes. The crosshairs on the probe indicate the sensor centers.
10. Record the X, Y and Z fields measured by the FVM400.
11. Rotate the object 180 degrees about its Z axis until the object's X and Y axes arrows are pointing in opposite directions to those of the probe. Make sure the geometric center of the object remains in the same location.
12. Record the X, Y and Z fields measured by the FVM400.
13. Rotate the object back to its original position. The field values should be the same as recorded in step 10.
14. Flip the object over so that the X and Z axes arrows of the object are pointing in opposite directions to the corresponding probe axes arrows. The Y axis of the probe and object should be pointing in the same direction.
15. Record the X, Y and Z fields measured by the FVM400.
16. Move the object one inch away from the probe along the extension of the probe's X axis. Place the object so that the X, Y, Z arrows of the object point in the same direction as the X, Y, Z arrows of the probe, and repeat steps 10 through 15.

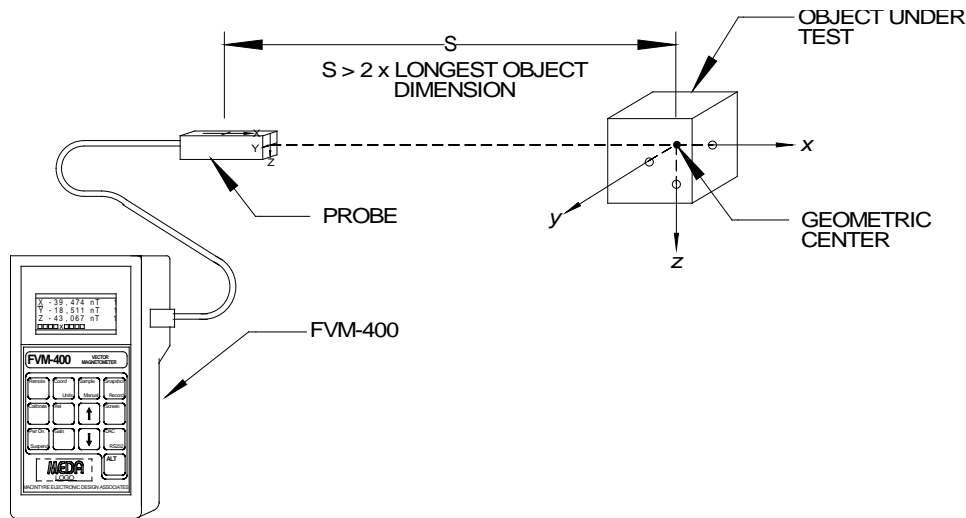

*Figure 7 Starting position when measuring the magnetic moments of an object*

**Data Reduction**

The field measurements, at different distances from the probe, are used to verify that the magnetized object can be modeled as a dipole. If the dipole model is correct, a plot of the data will reveal that the strength of the field is diminishing at a rate of  $1/r^3$ . The distance measured in step 9 for the X axis will be 0.5 inches longer than that for the Y and Z axes, since the X sensor center is further away than the Y and Z sensor center. This must be taken into account when plotting the data.

It is also possible that the geometric center of the object is not its magnetic center. Shifting the origin of the plotted values until the data agrees with a  $1/r^3$  relationship will usually reveal where the magnetic center lies. An estimate of the shift can be calculated from two measurements using the following equation:

$$d = \frac{(s_2 - s_1 \cdot (R_1/R_2)^{1/3})}{[(R_1/R_2)^{1/3} - 1]}$$

where  $R_1$  and  $R_2$  are the readings at distances  $s_1$  and  $s_2$ , respectively, and  $d$  is the amount to add to or subtract from the distance measurements to correct for the difference between the magnetic and geometric centers.

Compute the components of the permanent magnetization dipole moment using the following equations:

$$\begin{aligned}m_{x_p} &= (X_0 - X_{180}) \cdot r^3 / 4 \\m_{y_p} &= (Y_0 - Y_{180}) \cdot r^3 / 2 \\m_{z_p} &= (Z_0 - Z_{180}) \cdot r^3 / 2\end{aligned}$$

where  $X_0$ ,  $Y_0$ ,  $Z_0$  are the initial field measurements before the object is rotated,  $X_{180}$  and  $Y_{180}$  are the  $X$  and  $Y$  field measurements after the object has been rotated 180 degrees about the  $Z$  axis (step 11), and  $Z_{180}$  is the  $Z$  axis field measurement after the object has been flipped (step 14). The distance  $r$  is the distance from the appropriate probe sensor to the object's geometric center.

Compute the components of the induced magnetization dipole moment using the following equations:

$$\begin{aligned}m_{x_i} &= (X_0 + X_{180}) \cdot r^3 / 4 \\m_{y_i} &= (Y_0 + Y_{180}) \cdot r^3 / 2 \\m_{z_i} &= (Z_0 + Z_{180}) \cdot r^3 / 2\end{aligned}$$

The meanings of the  $X$ ,  $Y$  and  $Z$  measurements are the same as described for the permanent magnetization dipole moment component calculations.

## THEORY OF OPERATION

This section describes how the FVM400 operates. Figure 8 is a functional block diagram of the FVM400.

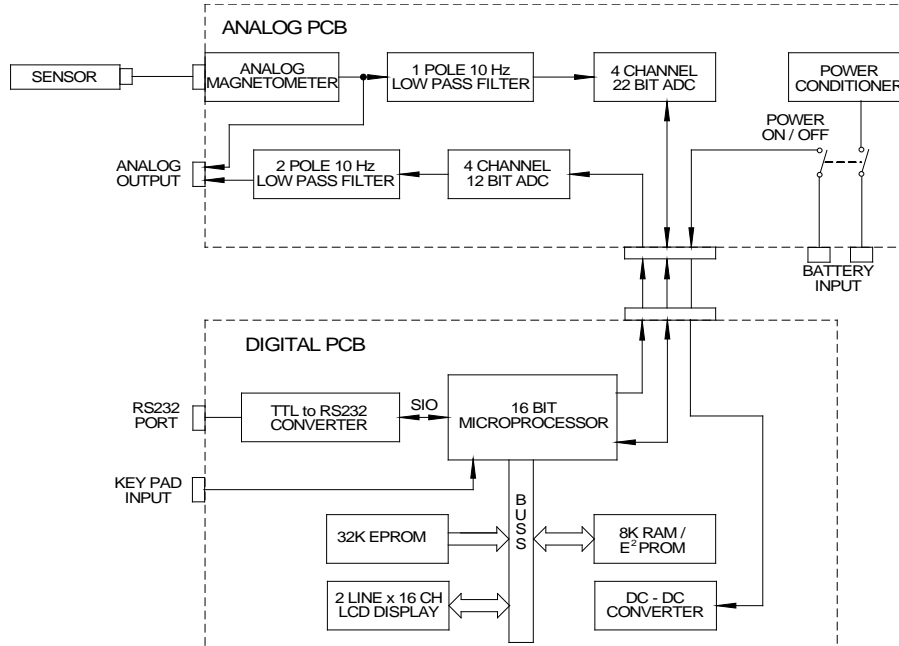

Figure 8 FVM400 functional block diagram

The FVM400 consists of three major functional elements: the sensor unit, the analog printed circuit board (PCB) and the digital PCB. The sensor unit contains two fluxgate sensor elements that measure the three orthogonal components of the magnetic field. The analog magnetometer provides the sensor drive signals and processes the sensor output signals. The outputs of the analog magnetometer are three analog voltages. The magnitudes and polarities of these signals represent the magnitudes and directions of the three magnetic field vector components. These signals are available through the analog output connector along with the microprocessor processed signals.

Each of the analog magnetometer signals is passed through a single pole 10 Hz low pass filter before being applied to an input of the 4 channel 22 bit analog-to-digital (ADC) converter. These filters, along with digital filters in the ADC, minimize any aliasing by signals with frequencies that are beyond the Nyquist frequency of the ADC.

The ADC outputs are transferred to the microprocessor board where scale factor, zero offset and alignment corrections are made. The polar coordinates are computed from the corrected rectangular components. These corrected and computed component values are averaged, and then the vector components are displayed on the 4 line by 16 character LCD display at a rate of 2 samples per second.

Communication with a remote computer or terminal is through a three wire RS232 connection. The TTL-to-RS232 converter translates TTL level signals to RS232 level and vice versa. When the operator places the FVM400 into remote operation, measurements are suspended, and the FVM400 waits to receive commands from a remote terminal or computer. When the FVM400 is in its normal local operating mode, the TTL-to-RS232 converter is turned off to conserve power.

The 32 kilobyte EPROM holds the FVM400 operating program. The 8 kilobyte RAM provides temporary storage required by the program and also for the data recorded using the *Snapshot*, *Record* and *Manual* sampling functions. The RAM also has a shadow EEPROM that stores the RAM data in nonvolatile memory when the FVM400 is turned off and restores the data when the FVM400 is turned back on.



The FVM400 samples the magnetic field data at a rate of 69.75 samples per second. The corrected data is output to the 4 channel 12 bit digital-to-analog converter (DAC) at the same rate. The outputs of the DAC are passed through two pole 10 Hz low pass filters before going to the analog output connector. The combined 10 Hz input filter and 10 Hz output filter form a critically damped four pole Butterworth filter.

The data that is sent to the DAC depends on the selected coordinate system and the gains chosen for the individual components. If the rectangular coordinate system is selected, the (X, Y, Z) components are processed and sent to the DAC. If the polar coordinate system is selected, the (R, D, I) components are processed and sent to the DAC. The values sent to the DAC also depend on the selected mode and gain for each component. The mode determines whether the signal is the actual or relative value of the component, and the gain determines the scale factor of the output voltage. See the section on the *Gain* function for an explanation of the relationship between gain and the DAC output signal.

**Fluxgate Theory**

The heart of the magnetometer is the fluxgate. It is the transducer that converts a magnetic field into an electrical voltage. The FVM400 uses two ring core fluxgates to measure the three components of the magnetic field. One ring core contains a single signal winding and measures the X component. A second ring core contains two orthogonal windings and measures the Y and Z components.

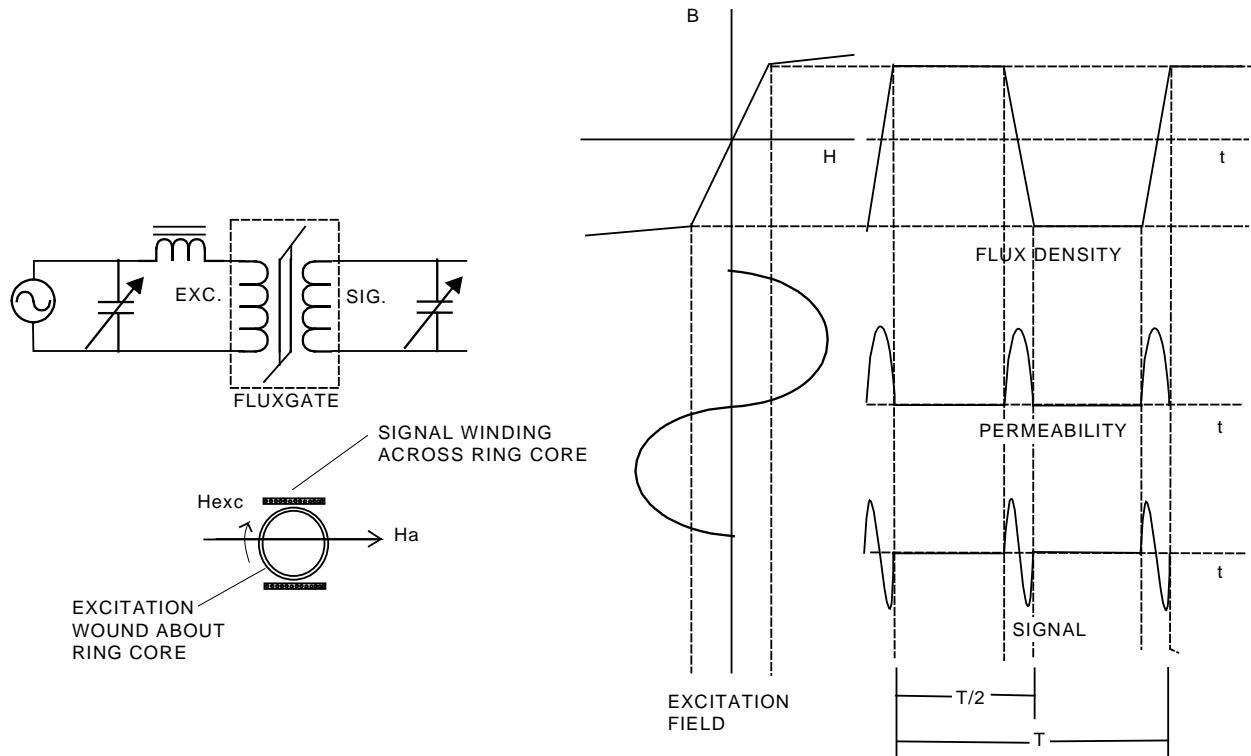

Figure 9 Ring core fluxgate operation

The ring core fluxgate is constructed from a thin ribbon of easily saturable ferromagnetic material, such as 4-79 Permalloy wrapped around a bobbin to form a ring or toroid. As shown in Fig. 8, an alternating current is applied through a coil which is wound about the toroid. This creates a magnetic field that circulates around the magnetic core. This magnetic field causes the flux in the ferrous material to periodically saturate first clockwise and then counterclockwise. A pickup (signal) winding is wrapped around the outside of the toroid. While the ferrous material is between saturation extremes, it maintains an average permeability much greater than that of air. When the core is in saturation, the core permeability becomes equal to that of air. If there is no component of magnetic field along the axis of the signal winding, the flux change seen by the winding is zero. If, on the other hand, a field component is present along the signal winding axis, then each time the ferrous material goes from one saturation

extreme to the other, the flux within the core will change from a low level to a high level. According to Faraday’s law, a changing flux will produce a voltage at the terminals of the signal winding which is proportional to the rate of change of flux.

As the core permeability alternates from a low value to a high value, it produces a voltage pulse at the signal winding output which has an amplitude that is proportional to the magnitude of the external magnetic field and a phase that indicates the direction of the field. The frequency of the signal is twice the excitation frequency, since the saturation-to-saturation transition occurs twice each excitation period.

**Analog Magnetometer**

The signal from the fluxgate is an amplitude-modulated suppressed carrier signal that is synchronous with the second harmonic of the excitation signal. A simplified schematic of the FVM400 analog fluxgate magnetometer is shown in Fig. 10. The circuitry to the left of the sensor is called the excitation circuit. It consists of an oscillator tuned to twice the excitation frequency, a flip-flop which divides the oscillator frequency by two and a power amplifier which is driven by the flip-flop and, in turn, provides the excitation current to the excitation winding.

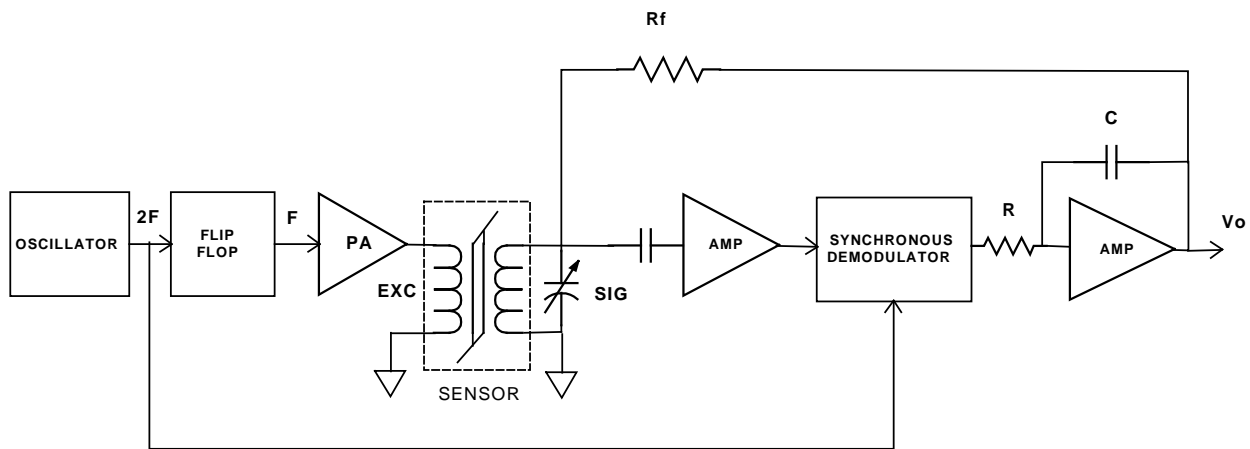

Figure 10 Simplified block diagram of one channel of the FVM400

The circuitry to the right of the fluxgate is called the signal channel circuit. It amplifies the output from the fluxgate signal winding, synchronously demodulates the AC signal using the oscillator signal as a reference, integrates and amplifies the base band output and then feeds back the output through a resistor to the signal winding. The fed back signal produces a magnetic field inside the sensor which opposes the external field. This keeps the field inside the sensor near zero and in a linear portion of the magnetization curve of the ferromagnetic core.

Under these circumstances, the transfer function becomes almost completely determined by the ratio of the feedback resistor to the current-to-field coil constant of the sensor winding. Both of these constants can be very well controlled. The consequence of this circuit topology is a highly stable and accurate magnetometer that is insensitive to circuit component variations with temperature or time.

**Signal Processing**

Figure 11 is a block diagram that shows how the analog signals received from the analog magnetometer are processed. The analog signals are first passed through a 10 Hz two pole Butterworth low pass filter to reduce aliasing that can occur because of the sampling process. The filtered data is sampled by the ADC at a rate of 550 kHz and then digitally low pass filtered at a corner frequency of 73 Hz. The transfer function for the digital filter is

$$|H(f)| = \left[ \frac{\sin \pi f / f_s}{\pi f / f_s} \right]^3$$

where  $f_s$  is the output rate (279 Hz) and  $f$  is the signal frequency.

## FVM400 VECTOR MAGNETOMETER

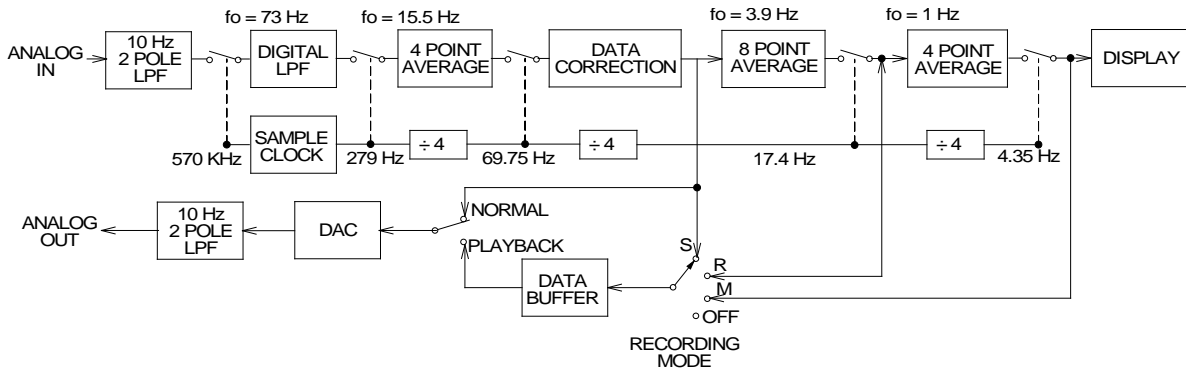

Figure 11 FVM400 signal processing block diagram

The ADC outputs are digitally filtered through an 8-point averager that has a corner frequency of 15.5 Hz. The output of this filter is sampled at a rate of 69.75 samples per second, then the data is corrected for gain, zero offset and angular alignment. When not playing back recorded data, the corrected field component values are sent to the DACs. The DAC output signal is either the absolute or relative value of the component multiplied by the operator selected DAC gain. This is the signal that is recorded if the operator selects the *Snapshot* function.

The corrected data is passed through another 8-point averager with a corner frequency of 3.9 Hz. The output rate of this filter is 17.4 samples per second. This is the signal that is recorded if the operator selects the *Record* function. An 8-point average of this signal is displayed on the LCD at a rate of 2 samples per second. The displayed signal is recorded whenever the operator is in the *Manual* sample mode and the *Sample* key is pressed.

## MAINTAINANCE

This section provides information on how to maintain the FVM400.

### **Sensor Probe**

The sensor probe is not watertight and should not be immersed in water. When working in the field in inclement weather, it is a good idea to place the sensor in a protective case, such as a plastic bag, that prevents water from entering the sensor through the connector.

Never place the sensor probe close to a source of a large magnetic field such as a magnet. This can cause the zero field reading to be permanently shifted and require the sensor to be demagnetized in order to restore it to its original condition.

Do not drop the sensor onto a hard surface, strike it with a hammer or suspend it from its cable. All of these actions can produce permanent damage to the sensor.

### **Electronics Unit**

Like the probe, the electronics unit is not watertight and should be protected from moisture penetrating into the case interior.

**DO NOT OPEN THE ELECTRONICS UNIT. THE USER CANNOT REPAIR THE FVM400 WITHOUT INVALIDATING ITS CALIBRATION STATUS. IF THERE APPEARS TO BE A PROBLEM WITH THE INSTRUMENT, CALL MEDA FOR TECHNICAL SUPPORT.**

### **Battery Replacement**

The FVM400 contains two batteries that are located under the lid on the back of the electronics unit. The battery section marked DIGITAL powers the digital PCB. The second battery powers the analog PCB. Both batteries are conventional 9-Volt batteries. Table 6 lists the recommended replacement batteries. The Lithium battery provides the longest life, but the FVM400 will operate properly with any of these batteries. The digital PCB requires more power than the analog PCB, therefore, it is probable that its battery will need to be replaced more often. Using an Alkaline battery for the analog PCB and a Lithium battery for the digital PCB will make the two batteries have closer to the same lifetimes.

*Table 6 FVM400 replacement batteries*

<b>Manufacturer</b>	<b>Part Number</b>	<b>Type</b>
Eveready	No. 522	Alkaline
Duracell	MN1604	Alkaline
Eveready	E146X	Mercuric Oxide
Ultralife	U9VL	Lithium

### **Cleaning Sensor Connectors and Cable Contacts**

Over time the contacts of the two (2) sensor cable connectors and the contacts in the mating connectors in the electronics unit and sensor may become dirty or oxidized. This situation may cause the FVM400 performance to deteriorate. If **O.L.** appears on the display after turning the power switch to the ON position, it may be caused by contact contamination. If changing the sensor position and turning the power ON and OFF does not return the FVM400 to its normal operating conditions, use the following procedure to clean the contacts:

1. Pour some Isopropyl alcohol over the contacts being cleaned.

2. Gently scrub the contacts with a Q-Tip or small stiff bristle brush, using a back and forth motion.
3. After scrubbing, allow the contacts to dry for a minimum of ten (10) minutes.
4. If compressed air is available, the contacts may be blown dry, and the FVM400 may be immediately used.

It is good practice to clean the contacts of the sensor cable connectors and their mating connectors before using the FVM400 whenever the FVM400 has been unused for an extended period of time.

### ***Battery Eliminator***

Included with the FVM400 is an AC adaptor that can be used instead of batteries to power the magnetometer. The AC adaptor is designed for North American use. It requires an input of 120 VAC at 60 Hz and has a regulated output voltage of 9 VDC and a current capacity of 200 mA. The output connector is a standard 2.1x5.5 mm DC power jack with a positive outer conductor. Outside of North America the user may need to purchase an adaptor plug or an alternate AC adaptor. The output voltage of the adaptor should be regulated and conform to the connector specifications described above.

**WARNING: UNDER NO CIRCUMSTANCE SHOULD THE USER APPLY AN INPUT VOLTAGE OF GREATER THAN 12 VOLTS DC. THIS COULD PERMANENTLY DAMAGE THE FVM400 REQUIRING IT TO BE RETURNED TO MEDA FOR REPAIR.**

### ***Calibration Schedule***

The FVM400 will remain within specifications for at least one year. The FVM400 should be recalibrated annually to assure that its performance remains within specifications. MEDA can perform the calibration that includes a Certificate of Calibration traceable to the National Institute of Standards and Technology (NIST).

## **WARRANTY**

This instrument is warranted by Macintyre Electronic Design Associates, Inc. (MEDA) to be free from defects in materials and workmanship. If a defect is discovered within one (1) year from date of purchase, MEDA will service the instrument as long as the original purchaser returns it to our factory. The original purchaser must prepay all transportation charges and demonstrate that the defect is covered by this warranty. Model and serial number must be supplied for service.

If the cause of the instrument failure is found to be misuse or abnormal operating conditions, repairs will be billed at cost upon authorization from the customer.

Under no circumstances will MEDA's liability exceed the cost to repair or replace the defective parts. MEDA's liability will cease and terminate at the completion of the one year warranty period.